



PERFOREX CUSTOM MODIFICATION



QUALITY



FLEXIBILITY



COMPLIANCE

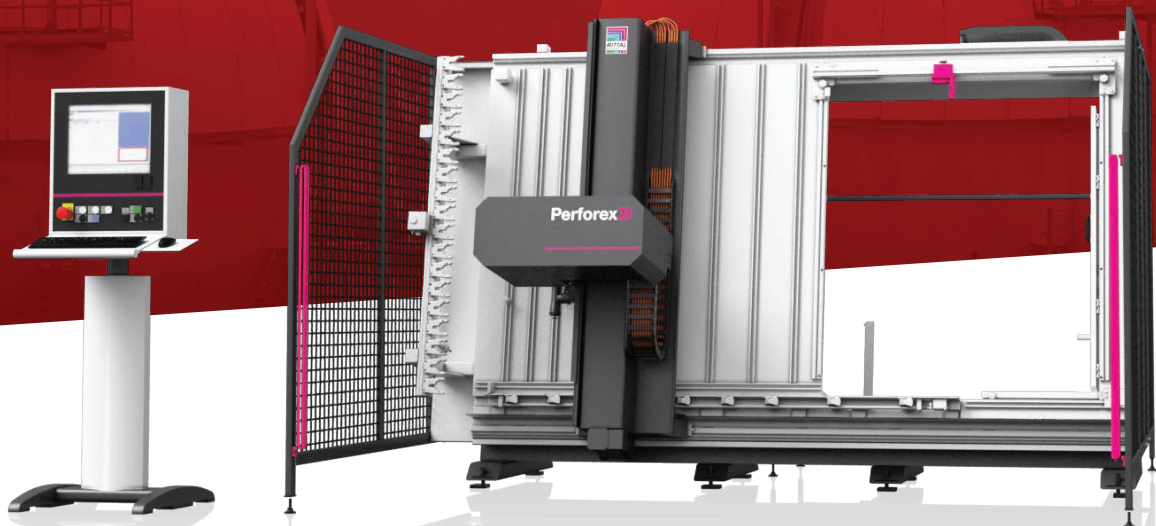

CUSTOM FROM STANDARD

MODIFICATION PROGRAM FOR STEEL, PLASTIC AND STAINLESS STEEL WALLMOUNTS, JUNCTION BOXES AND LARGE ENCLOSURES

As the national distributor of Rittal enclosures, we realize that you may have a project that demands something different. Our APS Modification service may be the solution.

Small, medium and large enclosures can be cut out to your specification and whether it is a cut out for a fan and filter, push buttons or multi-pole connectors, our Perforex machine and skilled modification team will modify to your exact specifications.

To place an order, reference the Rittal part number (xxxx.xxx) and attach the necessary drawings. We accept files in Eplan, DWG, DXF, or Rittal Configurator formats.

Please ensure that all cutouts, holes, and thread specifications are clearly indicated.

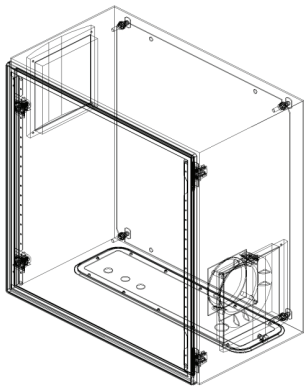

FANS & FILTERS

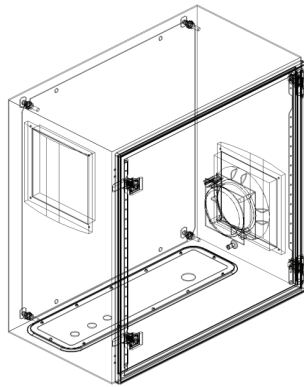

INTERNAL ASSEMBLY

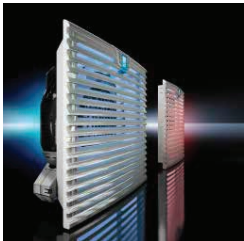

CABLE MANAGEMENT SYSTEMS



ACCESS PORT & FLAPS



AIR-CONDITIONERS

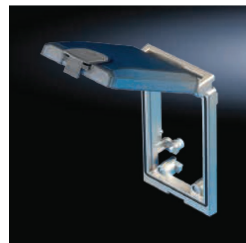

PLINTHS

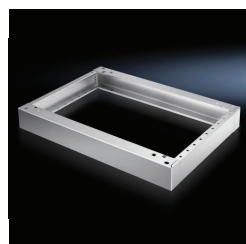

CUSTOMISATION IS A NECESSITY FOR MOST INSTALLATIONS

Provide us with detailed drawings and explanations outlining which accessories you need and where you want them.

We'll install:

- | Fans and filters
- | Heat exchangers
- | Air conditioners
- | Partial doors
- | Cable Management Systems
- | Wiring Plan Pockets
- | Partial Mounting Plates
- | Chassis and Support Rails
- | Lights and switches
- | Conduit and Cable Glands
- | 19" Installations
- | APS Supplied Push Buttons and Switches
- | Access ports/flaps

If no location is specified, we'll install accessories in default locations for the following:

- | Plinth/base/legs
- | Doors and walls
- | Handles and inserts
- | Roofs and cover plates
- | Full-size mounting panels
- | Inner doors

FAST AND RELIABLE MACHINING AND ASSEMBLY SERVICE

MODIFICATION CENTRE

When it comes to industrial enclosures, one size does not fit all. Each application is unique, every industry has its own demands and requirements, and companies striving to compete on a global stage or in a variant-rich marketplace must be flexible and agile to respond to unpredictable market forces.

APS's commitment to industry-leading products and services goes beyond supplying modular enclosures. We offer best-in-class custom modifications that not only help companies meet the demands of their industry but also aid in better understanding their business potential and goals by reengineering their value chain.

This is where APS's value proposition as a partner in the industrial enclosure and automation space becomes clear. Simply put, we supply the most efficient and durable enclosures on the market, and we customize them to exact specifications in a cost-effective and scalable manner.

STATE-OF-THE-ART EQUIPMENT

Perforex MT2201S:

A 4-axis CNC machine renowned for its precision and Reliability.

Automated Machining:

Ensures accuracy and consistency in every cut.

Wide Work-piece Holder:

Perfect for handling fully welded enclosures.



VERSATILE CAPABILITIES

Hole Drilling:

Perfectly positioned and accurately sized holes.

Tapping:

Flawless tapping of threads for secure fastening.

Cut-Outs:

Custom shapes and sizes to meet your specific requirements.

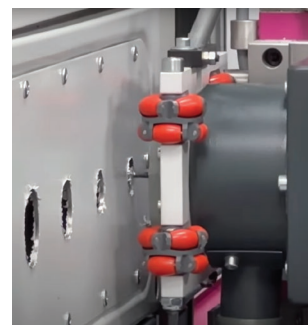
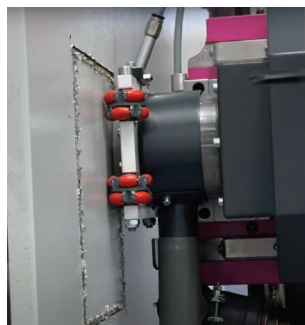

COST-EFFECTIVE

Reduce Manual Labor:

Save on time and labour costs with our automated system.

IDEAL FOR VARIOUS APPLICATIONS

Electrical Enclosures, Control Panels, Junction Boxes

CONFIGURATION MADE EASY

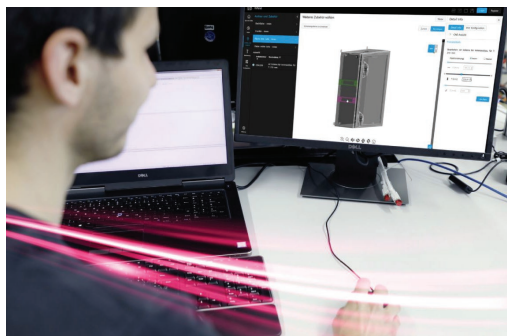

Large industrial enclosures

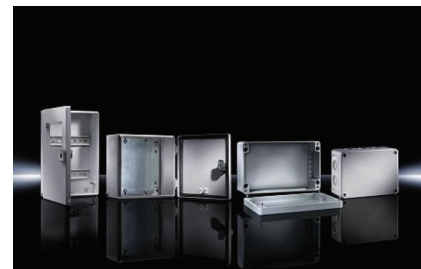

Small and compact enclosures

rittal.com/au-en/Rittal-Configuration-System





OUR LOCATIONS

National footprint with strategic local stockholdings.

APS Industrial is headquartered in Melbourne and in addition has a national network of offices in Adelaide, Perth, Sydney, Brisbane and Tasmania supported by strategic local stockholdings and expert technical and application knowledge.

apsindustrial.com.au

CONNECT WITH US



MELBOURNE

5-7 Corporate Ave,
Rowville, Melbourne VIC 3178
Ph: (03) 8514 3500
Sales: 1300 309 303
Email: vic@apsindustrial.com.au

SYDNEY

Unit P1, 10-16 South Street
Rydalmere, Sydney NSW 2116
Ph: (02) 8898 6200
Sales: 1300 309 303
Email: nsw@apsindustrial.com.au

BRISBANE

49 Borthwick Avenue,
Murarrie, Brisbane, QLD, 4172
Ph: (07) 3063 3100
Sales: 1300 309 303
Email: qld@apsindustrial.com.au

ADELAIDE

159-163 Caulfield Ave,
Clarence Gardens SA 5039
Ph: (08) 8111 5100
Sales: 1300 309 303
Email: sa@apsindustrial.com.au

PERTH

5 Glyde Court, Malaga,
Malaga, Perth WA 6090
Ph: (08) 6118 5300
Sales: 1300 309 303
Email: wa@apsindustrial.com.au

HOBART

441A Macquarie Street,
South Hobart, TAS, 7004
Sales: 1300 309 303
Email: tas@apsindustrial.com.au