



POWER QUALITY SOLUTIONS

Power Factor Correction | Capacitors | Grid Analysis
Controllers | Accessories | Active Harmonic Filtering



CONTENTS

Power Quality Solutions	3
General Overview	3
Range Overview	3
Power Factor Correction	4
How reactive power is generated	4
Power Factor Low Power Factor ($\cos \Phi$)	4
Power Factor Improvement	4
Types of PFC (detuned or conventional)	4
Power Factor Correction Capacitors	5
Power Factor Controllers	6
Grid Analysis Tool	7
Accessories	8
Contactors	9
Reactors – Antiresonance Harmonic Filter	9
Power Factor Correction Accessories	10
Power Quality Solutions	11
Power Factor Correction Functional Trays	11
MV Solutions	12
Static VAr Generator	13
Operating principle of SVG PQvar Series	13
General information	14
Technical data and specifications of low-voltage SVG PQvar Series 400 V	15
Active Harmonic Filtering	17
Active Harmonic Filter - PQSine S Series	20
EMC Components	21

POWER QUALITY SOLUTIONS

General Overview

The increasing demand of electrical power and the awareness of the necessity of energy saving is very important these days. Also the awareness of power quality is increasing and power factor correction (PFC) and harmonic filtering will be implemented on a growing scale. Enhancing power quality – improvement of power factor – saves costs and ensures a fast return on investment. In power distribution, in low- and medium-voltage networks, PQS focuses on the power flow ($\cos \Phi$) and the optimization of voltage stability by generating reactive power and compensation current to improve voltage quality and reliability at distribution level.

APS Industrial offers a comprehensive range on Electrical and Electronic components, equipment and services for the modern Power Factor Correction switchboard, Active Harmonic Filter Panel and Power Distribution Boards. We can measure and analyse from simple to complex electrical systems and offer PFC and/or AHF components or systems to rectify bad power factor and neutralise harmful harmonics.

Range Overview

Active Harmonic Filters and Static VAr Generators

- | New approach to harmonic filters power factor correction and load balancing
- | Fast response time < 15 ms, with dynamic reaction time less than 50 μ s
- | Modular design, compact structure, small footprint, simple operation, easy maintenance



PFC Controllers

- | Three phase measuring and controlling
- | Intelligent control
- | Automatic initialization
- | Logs and stores alarms
- | Four quadrant controller
- | LED & OLED display



PFC Functional Trays

- | Capacitors rated at 525Vac for 415Vac systems
- | 6.25; 12.5; 25 and 50kVar trays available
- | Siemens Fuses and Fuse Switches
- | AC6b rated Contactors
- | 7% Detuned reactors

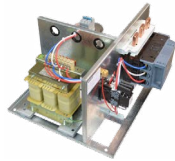

LV PFC Capacitors

- | Self-healing Metalized Film
- | Dry or Soft Resin
- | Up to 200 000h life expectancy
- | IEC 60831-1/2 and UL 810-5th edition approved



Complete PFC Panels

- | Automatic multistep systems
- | IP32 to IP54
- | Floor Standing or Wall Mounted
- | 6.25; 12.5; 25 and 50kVar steps
- | Contactor or Thyristor switched
- | 7% Detuned (other options available)



Additional PFC Components

- | AC6b Contactors for Standard PFC
- | Thyristor Modules for Dynamic PFC
- | Detuned Harmonic Reactors
- | 3-Line LCL filters for power electronics
- | Power line filters for 3 phase systems
- | Sine-wave output filters for 3-phase systems



MV PFC Systems and Components

- | Fixed and Auto Switching systems
- | Power Capacitors
- | Surge Capacitors
- | Reactors
- | Vacuum Contactors
- | Capacitor Switches



Power Filtering Equipment

- | 3-Line LCL Filters for Power Electronics
- | Power Line Filters for 3 phase systems
- | Sine-wave output filters for 3-phase systems

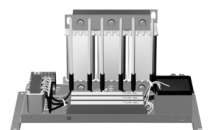
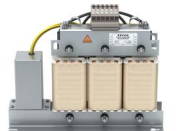

POWER FACTOR CORRECTION

How reactive power is generated

Every electric load that works with magnetic fields (motors, chokes, transformers, inductive heating, arc welding, generators) produces a varying degree of electrical lag, which is called inductance. This lag of inductive loads maintains the current sense (e.g. positive) for a time even though the negative-going voltage tries to reverse it. This phase shift between current and voltage is maintained, current and voltage having opposite signs. During this time, negative power or energy is produced and fed back into the network. When current and voltage have the same sign again, the same amount of energy is again needed to build up the magnetic fields in inductive loads. This magnetic reversal energy is called reactive power.

In AC networks (50/60 Hz) such a process is repeated 50 or 60 times a second. So an obvious solution is to briefly store the magnetic reversal energy in capacitors and relieve the network (supply line) of this reactive energy. For this reason, automatic reactive power compensation systems (detuned/conventional) are installed for larger loads like industrial machinery. Such systems consist of a group of capacitor units that can be cut in and cut out and which are driven and switched by a power factor controller.

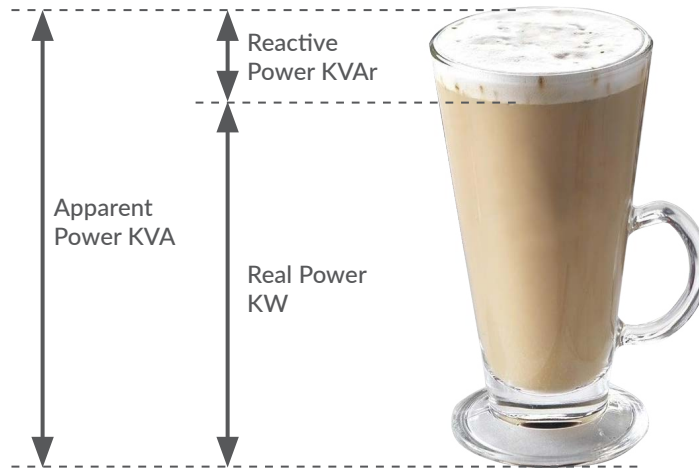

Power Factor

Low Power Factor ($\cos \phi$)

- | Low $\cos \phi$ results in higher energy consumption and costs,
- | less power distributed via the network,
- | power loss in the network,
- | higher transformer losses,
- | increased voltage drop in power distribution networks.

Power Factor Improvement

Power factor improvement can be achieved by

- | compensation of reactive power with capacitors,
- | active compensation – using semiconductors,
- | overexcited synchronous machine (motor/generator)

Types of PFC

(detuned or conventional)

- | individual or fixed compensation (each reactive power producer is individually compensated),
- | group compensation (reactive power producers connected as a group and compensated as a whole),
- | central or automatic compensation (by a PFC system at a central point), mixed compensation.

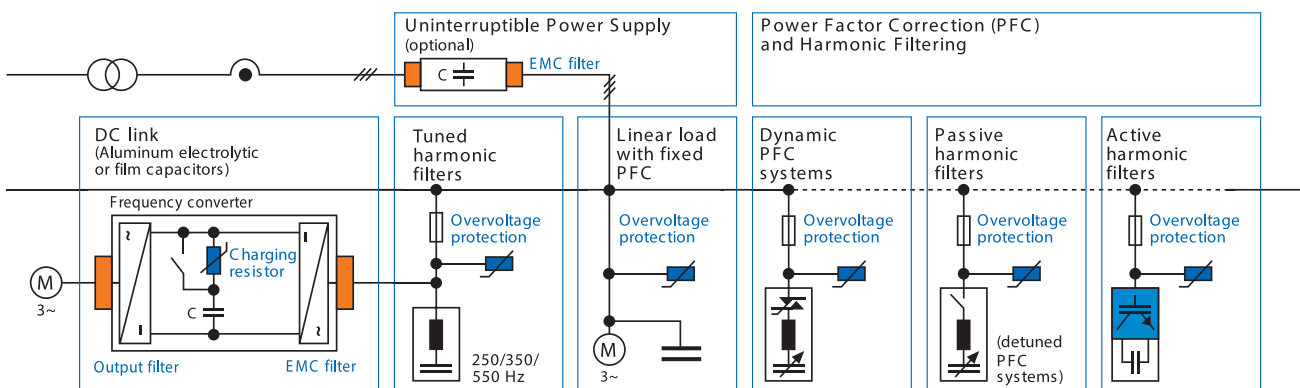

POWER FACTOR CORRECTION CAPACITORS

PFC capacitor series for power factor correction and detuned filter

PARAMETER	PHASECAP PREMIUM	PHICAP
POWER QR	5.0 ... 33.0 kVAr	0.5 ... 30.0 kVAr
RATED VOLTAGE VR	230 ... 800 Vac	230 ... 525 Vac
INRUSH CURRENT IS	Up to 300 * IR	Up to 200 * IR
TEMPERATURE CLASS	-40/D: Max: Temp. = 55 °C Max. Mean 24 h = 45 °C Max Mean 1 year = 35 °C Lowest Temp. = -40 °C	-40/D: Max: Temp. = 55 °C Max. Mean 24 h = 45 °C Max Mean 1 year = 35 °C Lowest Temp. = -40 °C
LOSSES - DIELECTRIC QL	< 0.2 W/kVAr	< 0.2 W/kVAr
LOSSES - TOTAL QL (WITHOUT DISCHARGE RESISTOR)	< 0.45 W/kVAr	< 0.45 W/kVAr
MAX. HUMIDITY	95%	95%
SAFETY	Triple (self-healing, overpressure disconnect, dry technology)	Duel (self-healing, overpressure disconnect)
IMPREGNATION	Inert Gas	Biodegradable soft resin, semi-dry
MEAN LIFE TLD (CO)	Up to 180 000 h (temp. class -40/C)	Up to 135 000 h (temp. class -40/C)
EXPECTANCY	Up to 130 000 h (temp. class -40/D)	Up to 100 000 h (temp. class -40/D)
CONNECTION	Optimised Capacitor Safety Terminal, Block-type	B32340/B32343 Series: Fats-on Terminals B32344 Series: Optimised Capacitor Safety Terminal, Block-type
DISCHARGE RESISTOR	Pre-Fitted	Pre-Fitted
COOLING	Natural or Forced	Natural or Forced
CASE / SHAPE	Aluminium / Cylindrical	Aluminium / Cylindrical
ENCLOSURE	IP20, indoor mounting, (optional IP54 with terminal cap)	B32340/B32343: IP00 B32344: IP20 (optional IP54 with terminal cap)
NUMBER OF SWITCHING OPERATIONS	Max. 7500 per year	Max. 5000 per year
STANDARD	IEC 60831-1+2, UL 810 5th edition, cUL file # E238746 (up to 690 V), GOST	IEC 60831-1+2, UL 810 5th edition, cUL file # E106388 CSA file # C22.2 N°190 MC #236094, (up to Ø 85mm), GOST
ORDERING CODE	B25667C*	B32340C* B32343C* B32344E*



KVAR @ 525VAC	PART NUMBER	KVAR @ 415VAC
PhaseCap Premium		
10 kVAr	B25667-C5127-A375	6.2 kVAr
20 kVAr	B25667-C5237-A375	12.5 kVAr
25 kVAr	B25667-C5287-A375	15.6 kVAr
PhiCap		
6.2 kVAr	B32344-E5071-A520	4 kVAr
10.4 kVAr	B32344-E5121-A520	6.5 kVAr
20 kVAr	B32344-E5202-A021	12.5 kVAr
25 kVAr	B32344-E5252-A021	15.6 kVAr

POWER FACTOR CONTROLLERS

Controllers for PFC are of major importance in the PFC system. They measure the actual power factor and connect or disconnect capacitor stages to achieve a specific desired value ($\cos \varphi$).

BR6000 OLED series

The PF controller series BR6000 (six and twelve stages) offer highly intelligent control behaviour and are very user-friendly thanks to menu-driven handling (plain language). Their multifunctional display greatly simplifies installation, handling and maintenance.

Different versions of the BR6000 series provide solutions to various applications:

BR6000-R6 and BR6000-R12 for conventional applications with slowly changing loads

BR6000-T6 for dynamic PFC in applications with fast-changing loads



BR7000/I OLED series

The PF controller BR7000 is a follow-up development of the PF controller BR6000-series, featuring two devices in one: it can be used as a controller as well as a grid measuring tool.

The BR7000 offers a graphic display and 12 or 15 relay outputs for the steps and message/alarm relays. Due to the possibility of programming, the outputs can be used for a broad range of applications.

The BR7000 15 step controller features 3 current inputs that enables it to switch a combination on single and three phase capacitors.

The controller can be connected to a PC via a RS485 interface. The Windows-based software BR7000-SOFT allows the readout of acquired data. The possibility of graphical display of all values offers a comfortable visualization.



Data Logger

DataLogSD for BR7000/I controllers – B44066-R1311-E230

The data logger is used for recording, visualisation and evaluation for grid parameters after installation of a PFC system with a BR7000 and BR7000i controllers.



Features:

- | Recording of grid parameters, switching behaviour and temperature values of a system
- | Visualisation and evaluation via comfortable
- | Windows-based software
- | Compact design in plastic casing
- | Evaluation software, SD-card, connection cable included in the delivery
- | No extra auxiliary voltage supply needed

PART NUMBER	DESCRIPTION
BR6000 CONTROLLERS WITH RELAY OUTPUTS AND OLED DISPLAY	
B44066-R6006-E230	BR6000 CONTROLLER 6 RELAY
B44066-R6012-E230	BR6000 CONTROLLER 12 RELAY
BR7000 CONTROLLERS WITH RELAY OUTPUTS GRAPHIC DISPLAY	
B44066-R7112-E230	BR7000i CONTROLLER 12 RELAY WITH RS485
B44066-R7415-E230	BR7000 CONTROLLER 15 RELAY WITH RS485
BR7000 CONTROLLERS WITH TRANSISTOR OUTPUTS GRAPHIC DISPLAY	
B44066-R7615-E230	BR7000 T/HD CONTROLLER 15 with RS485
DATALOGSD FOR BR7000/I CONTROLLERS	
B44066-R1311-E230	DataLogSD for BR7000

GRID ANALYSIS TOOL

The measuring device MC7000-3 has been developed for three-phase measuring, display and storage of electric parameters in low-voltage grids. The Windows based software (included in the delivery) allows a fast and comfortable evaluation of the measured data. Based on the findings of this evaluation the optimum design for a tailor-made PFC solution or the inspection of an existing one is easily performed. The collected data is available in Excel-format giving the user further processing options. As an additional feature the MC7000-3 is equipped with an SD memory card slot. A memory card (1 GB) for data storage and easy passing on to a PC is already included in the delivery. Featuring an illuminated 128 x 64 graphic display and a large number of configuration options for data collection, display and storage the new standard measuring tool is flexible and easy to use in the field. Additionally its compact design and the light weight suitcase make it easy to transport. A further benefit for very user is the availability of not only English, but also German, Spanish, Russian and Turkish as menu languages.



Services

These analysers are available for sale or APS Industrial can offer rental of the equipment with partial reimbursement if the analysis leads to the sale of Power Factor corrections systems or components.

Features

- | Measuring, display and storage of numerous parameters
- | Voltage (3-phase)
- | Current (3-phase)
- | Frequency (3-phase)
- | Active power (3-phase)
- | Reactive power (3-phase)
- | Apparent power (3-phase)
- | Power factor (3-phase)
- | Active, reactive and apparent energy
- | Voltage harmonics (up to 51st)
- | Harmonics of current (up to 51st)
- | TDH-V (3-phase)
- | THD-I (3-phase)
- | Temperature
- | Comfortable programming of recording interval and duration via timers
- | Display and internal storage of maximum values with time stamp
- | Display of date and time
- | Display of harmonics, bar diagram available
- | Large number of display options e.g. rotating display and adjustment of font size

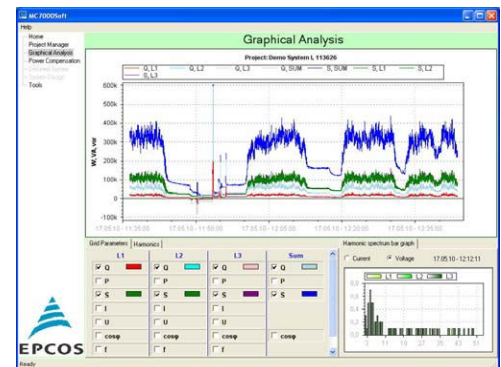

PC software included

- | Software for evaluation of grid parameters for Windows operating system
- | Administration of several projects possible
- | Graphical display
- | Several pre-configured graphical display of standard values
- | Graphical display of selected grid values, large number of configuration options
- | Comfortable editing of parameters and time interval
- | Display as line graph or bar diagram
- | Copy into clipboard and print function available
- | Mathematical evaluation of measured values
- | Automatic calculation of required kvar (target $\cos\phi$ to be set by user)
- | Evaluation of measured harmonics and recommendation of detuning factor of a PFC system of calculated size
- | Influence of detuning on the harmonics for the calculated detuning factor and system size is provided

ACCESSORIES

Thyristor Modules for Dynamic PFC

Conventional systems for power factor correction are used to optimize the power factor and reduce the level of harmonics in the grid. The usage of new technologies in modern industry has negative impacts on electric power quality of the main supply networks, e.g. frequent high load fluctuations and harmonic oscillation.

Excessive currents, increased losses and flickering will not only influence the supply capacity but will also have a significant impact on the operation of sensitive electronic devices.

The solution for this are dynamic power factor correction systems. With the thyristor module series TSM-LC and TSM-HV, we provide the main component – “the electronic switch” – for dynamic power factor correction. The TSM module

Applications for Thyristor Modules

Main supply networks with high load fluctuations for dynamic PFC systems

- | Presses
- | Welding machines
- | Elevators
- | Cranes
- | Wind turbines

Features of the Thyristor Modules

- | Easy installation: it can be used similar to a contactor
- | All the intelligence needed is offered within the thyristor module itself
- | Reaction time: 5 milliseconds only
- | Permanent self-controlling of:
 - voltage parameter
 - phase sequence
 - capacitor output
- | Display of
 - operation
 - faults
 - activation
- | TSM-LC-I:
 - Single-phase, for direct 2-phase switching of capacitive loads (L-N) or (L-L)
- | TSM-LC-S:
 - Triggering of the module via system bus (patch cable) from PF-controller BR7000-I-TH/S485
 - Up to 32 devices at supported by controller
 - Display and monitoring of V, I, Q, temperature, switching state
 - Error display and evaluation via bus directly at PF-controller
 - Direct monitoring of temperature switch of filter reactor
- | Voltage range:
 - TSM-LC-I: 230 ... 525 V
 - TSM-LC*: 380 ... 440 V
 - TSM-LC-S: 200 ... 440 V
 - TSM-LC-N690: 380 ... 690 V
 - TSM-HV: 690 V
- | Output range:
 - TSM-LC-I: 10 ... 22 kvar, depending on the voltage
 - TSM-LC: 10, 25, 50, 100, 200 kvar, depending on the voltage
 - TSM-HV: 200 kvar”



CONTACTORS

“When a capacitor is switched to an AC voltage, the result is a resonant circuit damped to a greater or lesser degree. The switching of capacitors can cause high inrush currents, particularly when they are switched in parallel to others already activated in the power line, and if high short-circuit powers are present on the line.

Capacitor contactors with damping resistors make use of preswitching auxiliary contacts. They close before the main contacts and pre-load the capacitor thus avoiding current peak values.”

Contactor Features

- | Excellent damping of inrush current
- | Improved power quality (e.g. avoidance of voltage sags)
- | Longer useful service life of main contacts of capacitor contactor
- | Soft switching of capacitor and thus longer useful service life
- | Enhanced mean life expectancy of PFC system
- | Reduced ohmic losses
- | Leading contacts with wiper function
- | Tamper-proof and protected resistors
- | Easy access for cable connection
- | Voltage range: 400 ... 690 V
- | Output range: 12.5 ... 100 kvar
- | AC6b utilization category



Reactors – Antiresonance Harmonic Filter

General

The increasing use of modern power electronic apparatus (drives, uninterruptible power supplies, etc) produces nonlinear current and thus influences and loads the network with harmonics (line pollution).

The power factor correction or capacitance of the power capacitor forms a resonant circuit in conjunction with the feeding transformer.

Experience shows that the selfresonant frequency of this circuit is typically between 250 and 500 Hz, i.e. in the region of the 5th and 7th harmonics.

Such a resonance although can lead to the following undesirable effects:

- | overloading of capacitors,
- | overloading of transformers and transmission equipment,
- | interference with metering and control systems, computers and electrical gear,
- | resonance elevation, i.e. amplification of harmonics,
- | voltage distortion.

These resonance phenomena can be avoided by connecting capacitors in series with filter reactors in the PFC system. These so called “detuned” PFC systems are scaled in a way that the self-resonant frequency is below the lowest line harmonic. The detuned PFC system is purely inductive seen by harmonics above this frequency. For the base line frequency (50 or 60 Hz usually), the detuned system on the other hand acts purely capacitive, thus correcting the reactive power.”

Application

- | Avoidance of resonance conditions
- | Tuned and detuned harmonic filters
- | Reduction of harmonic distortion (network clearing)
- | Reduction of power losses

Features

- | High harmonic loading capability
- | Very low losses
- | High linearity to avoid choke tilt
- | Low noise
- | Convenient mounting
- | Long expected life time
- | Temperature protection (NC contact)
- | Typical Detuning Factors available:
 - | 5.67%
 - | 7% (Typically stocked)
 - | 14%
- | Custom Reactors available on request



POWER FACTOR CORRECTION ACCESSORIES

Contactors for standard switched PFC systems. 3 Phase, Inrush damping, soft switching, AC6b rated

KVAR @ 415VAC	PART NUMBER	AC COIL VOLTAGE
0 ... 13 kVAr	B44066-S1810-J230	230 Vac
10.5 ... 27 kVAr	B44066-S3210-J230	230 Vac
23 ... 53 kVAr	B44066-S6210-J230	230 Vac
10.5 ... 27 kVAr	B44066-S3210-J400	415 Vac
23 ... 53 kVAr	B44066-S6210-J400	415 Vac



Thyristor Modules for Dynamic PFC

KVAR @ 415VAC	PART NUMBER	RATED AC VOLTAGE
25 ... 50 kVAr	B44066-T3850-E402	380 ... 440 V
100 kVAr	B44066-T0100-E402	440 V



Accessories for Thyristor unit

KVAR @ 415VAC	PART NUMBER	DESCRIPTION
12.5 .. 50 kVAr	B44066-T0022-E400	EW22 Discharge Resistor

Reactors for Detuned Harmonic Filters - 7% Detuned

KVAR @ 415VAC	PART NUMBER	RATED AC VOLTAGE
6 kVAr	B44066-D7006-L440	440 V
12.5 kVAr	B44066-D7012-L440	440 V
25 kVAr	B44066-D7025-L440	440 V
50 kVAr	B44066-D7050-L440	440 V



Fuses and Fuse Switches an Busbar holder

KVAR @ 415VAC	PART NUMBER	DESCRIPTION
6 kVAr	3NA3805	LV HRC, 16 A, Size 000, 500V
12.5 kVAr	3NA3812	LV HRC, 32 A, Size 000 , 500V
25 kVAr	3NA3822	LV HRC, 63 A, Size 000 , 500V
50 kVAr	3NA3832	LV HRC, 125 A, Size 00, 500V
All	3NP1133-1BC10	Fuse Switch, Lug, 60mm, Busbar Mount, 160A, Size 00
All	8US1923-2AA01	Busbar End Holder, 3P, Outside Fixings



POWER FACTOR CORRECTION FUNCTIONAL TRAYS

Each PFC Functional tray consist of Capacitors, a Contactor, a Detuned Harmonic Reactor, Fused and a Fuse Switch

KVAR @ 415VAC	PART NUMBER	DESCRIPTION
6.25 kVAr	PFCT6WR	6.25 kVAr Tray complete with Harmonic Reactor
12 kVAr	PFCT12WR	12.5 kVAr Tray complete with Harmonic Reactor
25 kVAr	PFCT25WR	25 kVAr Tray complete with Harmonic Reactor
50 kVAr	PFCT50WR	50 kVAr Tray complete with Harmonic Reactor

The tray is in a format easily adapted to fixing in standalone boards or inside main switchboards.

Characteristics

- | Capacitor Rated Voltage 525V three phase 50Hz
- | Maximum permissible voltage increase; 10% (up to 8 hours daily), 15% (up to 30min daily)
- | Ambient Temperature; max 55 °C; max mean 24h = 45°C
- | Segregation between capacitors and reactor and contactor

Please contact your local APS Industrial Sales Representative to discuss your power factor project and its requirements. We can offer our services to measure and analyse problematic sites and offer components, trays or complete PFC panels to improve the Power Factor.

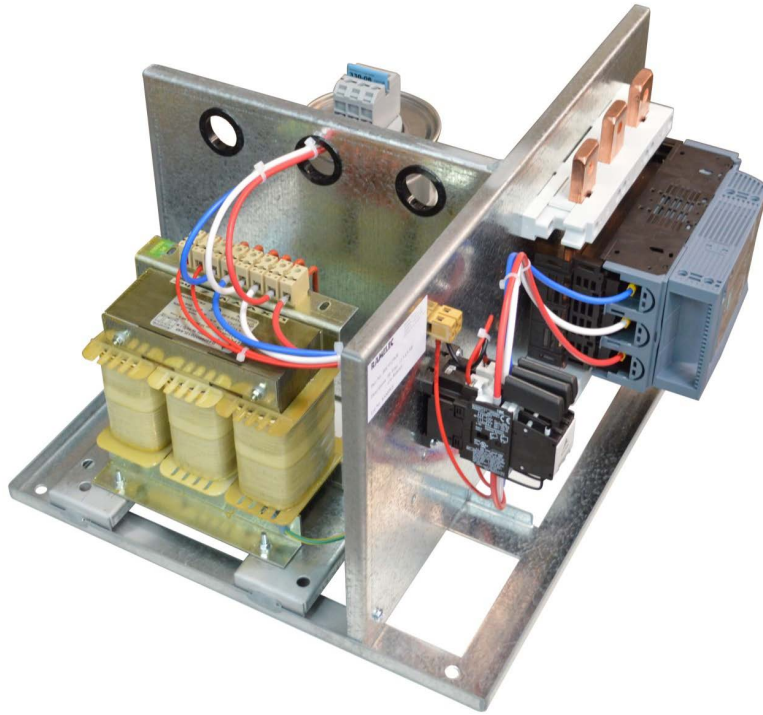

MV SOLUTIONS

Our latest addition to the APS Industrial - TDK line-up is power quality solutions and systems between 1kV and 33kV. In this sector we can offer:

- | MV PFC Capacitors
- | MV Surge Capacitors
- | MV Energy Storage Capacitors
- | MV Vacuum Contactor for Capacitor Switching
- | MV Vacuum Switches for Capacitor Switching
- | MV Series Reactors for Detuning, Damping and Current Limiting
- | MV Static VAR Generators
- | Complete MV Automatic PFC systems
- | Complete MV Tuned Harmonic Filters

Please contact your local APS Industrial Representative for further information.



STATIC VAR GENERATOR

EPCOS has been offering a comprehensive range of key components for Power Factor Correction (PFC) and Power Quality Solutions (PQS) for many years. The rapid development of industry and infrastructure resulted in the increased usage of power electronic loads which demands a highly dynamic response time for reactive power compensation. Conventional reactive power compensation only with passive components cannot fully meet these conditions, especially when the reactive power requirement is rapidly changing.

- | EPCOS Static Var Generator (SVG) PQvar Series utilizes three levels inverter topology to provide real time response to reactive power requirements)
- | EPCOS Static Var Generator (SVG) PQvar Series is a Flexible AC Transmission Systems (FACTS) controller, whose capacitive or inductive output current can be controlled independent of the AC system voltage.
- | SVG PQvar Series is a parallel device connected to the grid and the main circuit is based on a three phase voltage source converter (VSI) topology. External CT measures load current and external DSP helps to calculate and analyze the required reactive current.
- | SVG PQvar Series controls PWM signals and sends control message to IGBT modules which generate reactive current in order to improve system power factor.
- | SVG PQvar Series provides faster compensation compared to conventional compensation systems such as capacitor banks. Thus, it is an ideal solution especially for fast loads of inductive or capacitive behavior. It can compensate both inductive and capacitive reactive current without under or over compensation. Static Var Generator (SVG) PQvar™ Series
 - New approach to power factor correction and load balancing
 - Fast response time < 15 ms, with dynamic reaction time less than 50 μs
 - Precise compensation after compensating the target power factor can reach a value of unity
 - Capable of both inductive and capacitive compensation and will avoid under and over compensation issues
 - Minimal loss, better energy efficiency, long-term safe and reliable operation
 - Modular design, compact structure, small footprint, simple operation, easy maintenance



Operating principle of SVG PQvar Series

SVG PQvar Series generates a compensation current working as a dynamic current source, monitors the power factor value of power system, and generates real time compensation current in order to ensure to achieve the set target $\cos \phi$.

STEPLESS COMPENSATION

Unlike traditional stepped capacitor based PFC equipment, a SVG supplies stepless compensation

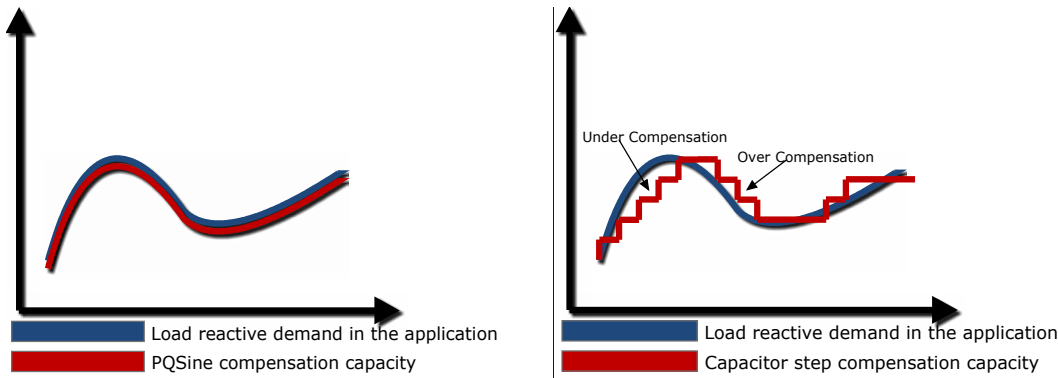

SVG PQvar Series load balancing for 3P3W and 3P4W

SVG PQvar Series can balance load between phases and unloaded neutral wire for input voltage connection systems such as three phase three wires (3P3W) and three phase four wires (3P4W). Therefore, it will be a perfect solution with applications having reactive power requirements along with unbalanced loads, which is the case with the electricity distribution in rural areas, some industrial applications and much more.

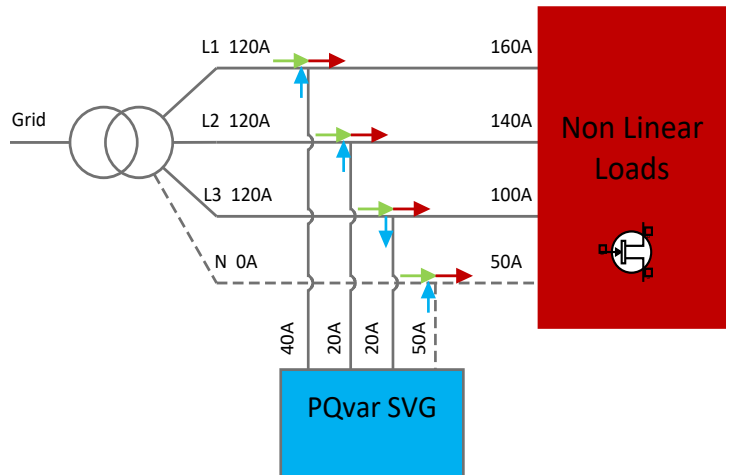

STATIC VAR GENERATOR

General information

SVG PQvar Series is a new product which has rewritten the conventional approach of power factor correction. It is designed to compensate the rapid reactive power requirement, thereby improving the power factor and consequently reducing the costs. SVG PQvar Series monitors the current signal and utilizes three levels inverter topology which generate the reactive part of the measured current to compensate dynamically in order to improve the power factor. It can dynamically compensate power factor from -1 to 1.

Features

- | SVG PQvar Series can be considered as a controllable reactive current source, which helps to improve the system power factor to a target value of more than > 0.99 without any over or under compensation.
- | SVG PQvar Series has extremely rapid dynamic compensation reaction time, which is less than $50 \mu\text{s}$ and a state response time of less than 15 ms.
- | SVG PQvar Series is an active compensation device, which doesn't need capacitor or reactor for reactive power compensation which will avoid the condition of resonance caused by the traditional capacitor banks.
- | SVG PQvar Series can compensate both inductive and capacitive reactive power and also provide load balancing.
- | SVG PQvar Series can compensate reactive power in any scope and can be installed together with traditional capacitor banks.
- | The grid voltage has no influence on the SVG PQvar Series compensation capacity. So even if the system voltage drops down, the required reactive power can be compensated by monitoring its requirement.
- | SVG PQvar Series can compensate for the same capacity equivalent to the installed capacity, therefore it requires 20 to 30% lower capacity in comparison with the conventional capacitor banks.

Typical applications

Some typical applications which require rapid reactive power compensation includes the following:

- | Data centers
- | UPS systems
- | Renewable power generation (e.g. photovoltaics and wind turbines)
- | Sensitive equipment manufacturing (e.g. silicon wafer production, semiconductor production)
- | Industrial production machines
- | Electrical welding systems
- | Plastic industry machinery (e.g. extruders, injection molders)

Safety features

- | Overload protection
- | Internal short-circuit protection
- | Overheating protection
- | Overvoltage and undervoltage protection
- | Inverter bridge protection
- | Fan fault alarm



Technical data and specifications of low-voltage SVG PQvar Series 400 V

RATED VOLTAGE	400 V; -40 ... +20%	
MAINS FREQUENCY	50/60 Hz (range: 45 ... 63 Hz)	
PARALLEL OPERATION	Unlimited	
RESPONSE TIME	< 15 ms	
OVERALL EFFICIENCY	> 97%	
POWER GRID STRUCTURE	3P3W / 3P4W	
CURRENT TRANSFORMERS	150/5 ... 10000/5	
CIRCUIT TOPOLOGY	3-level	
SINGLE-MODULE COMPENSATION CAPACITY	30/50 kvar	100/200 kvar
MODULE NET WEIGHT	21/35 kg	48/66 kg
DIMENSIONS (W × D × H)	30 kvar: 440 × 445 × 150 mm (module)	100 kvar: 500 × 470 × 270 mm (module)
	50 kvar: 500 × 510 × 190 mm (module)	200 kvar: 500 × 650 × 350 mm (module)
COOLING MODE	Smart air cooling: 220 L/sec	Smart air cooling: 405 L/sec
TARGET POWER FACTOR	Adjustable from -1 ... +1	
CABINET MOUNTING	Floor-mounted, wall-mounted	
COMMUNICATION PORTS	RS485, CAN, and network port	
COMMUNICATION PROTOCOLS	Modbus and PMBus	
NOISE LEVEL	< 65 dB (depending on the model)	
PROTECTION FUNCTIONS	Overvoltage, undervoltage, short-circuit, inverter bridge inverse, over-compensation	
OPERATING TEMPERATURE	-10 ... +40 °C (Up to 55°C with derating), other temperature ranges upon request	
RELATIVE HUMIDITY	5 ... 95%, non-condensing	
PROTECTION CLASS	IP20 (other IP classes are customizable)	
PANEL COLOR	RAL7035 light grey (X15 Orange on request)	
ALTITUDE	1500 m, 1% derating per 100 m plus	
GENERAL SAFETY REQUIREMENTS FOR SVG PQVAR SERIES USE AND OPERATION AREA	EN 50178:1997/ IEC 50178:1997	
SVG PQVAR SERIES EMC REQUIREMENTS	EN 61000_6_2(2005)/ EN55011, GROUP1, CLASS A	
	IEC 61000_6_2(1999)/ CISPR11, GROUP1, CLASS A	
SVG PQVAR SERIES PERFORMANCE REQUIREMENTS	EN 50091-3/ IEC 62040-3/ AS 62040-3(VFI SS 111)	

Technical data and specifications of low-voltage SVG PQvar Series 400 V

PART NUMBER	DESCRIPTION
3 PHASE 3 WIRE - WALL MOUNT	
B44066F6030V344	PQSW6030V344 30kVAr 3P3W Wall mount
B44066F6050V344	PQSW6050V344 50kVAr 3P3W Wall mount
B44066F6100V344	PQSW6100V344 100kVAr 3P3W Wall mount
B44066F6200V344	PQSW6200V344 200kVAr 3P3W Wall mount
3 PHASE 4 WIRE - WALL MOUNT	
B44066F8030V344	PQSW8030V344 30kVAr 3P4W Wall mount
B44066F8050V344	PQSW8050V344 50kVAr 3P4W Wall mount
B44066F8100V344	PQSW8100V344 100kVAr 3P4W Wall mount
B44066F8200V344	PQSW8200V344 200kVAr 3P4W Wall mount
3 PHASE 3 WIRE - FLOOR STANDING	
B44066F6100V315	PQSF6100V315 100kVAr 3P3W Floor Standing
B44066F6200V315	PQSF6200V315 200kVAr 3P3W Floor Standing
B44066F6250V315	PQSF6250V315 250kVAr 3P3W Floor Standing
B44066F6300V315	PQSF6300V315 300kVAr 3P3W Floor Standing
B44066F6400V315	PQSF6400V315 400kVAr 3P3W Floor Standing
B44066F6500V315	PQSF6500V315 500kVAr 3P3W Floor Standing
B44066F6600V315	PQSF6600V315 600kVAr 3P3W Floor Standing
B44066F6800V315	PQSF6800V315 800kVAr 3P3W Floor Standing
3 PHASE 4 WIRE - FLOOR STANDING	
B44066F8100V315	PQSF8100V315 100kVAr 3P4W Floor Standing
B44066F8200V315	PQSF8200V315 200kVAr 3P4W Floor Standing
B44066F8250V315	PQSF8250V315 250kVAr 3P4W Floor Standing
B44066F8300V315	PQSF8300V315 300kVAr 3P4W Floor Standing
B44066F8400V315	PQSF8400V315 400kVAr 3P4W Floor Standing
B44066F8500V315	PQSF8500V315 500kVAr 3P4W Floor Standing
B44066F8600V315	PQSF8600V315 600kVAr 3P4W Floor Standing
B44066F8800V315	PQSF8800V315 800kVAr 3P4W Floor Standing
EXTRA MODULES	
B44066F6030V300	PQSM6030V300 30kVAr 3P3W Module
B44066F6050V300	PQSM6050V300 50kVAr 3P3W Module
B44066F6100V300	PQSM6100V300 100kVAr 3P3W Module
B44066F6200V300	PQSM6200V300 200kVAr 3P3W Module
B44066F6030V300	PQSM8030V300 30kVAr 3P4W Module
B44066F6050V300	PQSM8050V300 50kVAr 3P4W Module
B44066F6100V300	PQSM8100V300 100kVAr 3P4W Module
B44066F6200V300	PQSM8200V300 200kVAr 3P4W Module
ACCESSORIES	
B44066F9999V230	7" HMI Colour

ACTIVE HARMONIC FILTERING

Today, most loads react non-linear. When connected to a sinusoidal voltage, these loads produce non sinusoidal currents which in turn creates distortion in the voltage supply called "Harmonic Distortion". The most widely used examples of non-linear loads today are Power electronics like Switch Mode Power Supplies which power our every day devices e.g. TVs, Laptops and Mobile Phone Chargers. In our industrial environment power electronics are used in Variable Speed Drives, Un-Interruptible Power Supplies and Arc devices like Arc Welders and Arc Furnaces.

The voltage distortion caused by these machines can lead to:

- | Additional investment due to faster equipment derating
- | Higher energy consumption
- | Higher downtime of production equipment
- | Higher maintenance and repair cost
- | Reduced product quality
- | Reduced production output

Solutions for reducing the harmonic content can be:

- | To increase fault level (reduction of impedances)
- | Limiting total output / simultaneously working harmonic sources
- | Balanced connection of 1-phase loads to the 3-phases
- | Using equipment with higher pulse number

Use harmonic filtering techniques:

- | De-tuned passive harmonic filters
- | Tuned passive harmonic filters
- | Active harmonic filters



EPCOS has been offering a comprehensive range of key components for power factor correction (PFC) and power quality solutions (PQS) for many years. In the past, most consumer loads were linear, i.e. when they were connected to a sinusoidal voltage, the current was also sinusoidal. In the meantime, the use of power electronics has significantly increased. These devices are usually non-linear, i.e. when connected to a sinusoidal voltage they produce non-sinusoidal currents which may create problems for other devices.

Besides passive filters, more and more active harmonic filters are now used, especially where the PF is close to 1 and harmonic disturbances change frequently.

The PQSine S-series of active filters and power optimizers from EPCOS:

- | Eliminate harmonics up to the 50th order
- | Offer dynamic VAR compensation
- | Balance the load actively to all phases
- | Offer high performance
- | Have a three-level topology
- | Improve power quality and enhance system reliability
- | Ensure integrated overload, overvoltage and undervoltage protection
- | Ensure low life-cycle costs thanks to a modular concept and low losses.

The cleaner the grid, the greater the benefit

EPCOS active harmonic filters and power optimizers help to eliminate harmonic pollution from the grid, reduce power quality problems and use energy more efficiently and reliably.

Harmonic pollution is a growing problem with the increasing use of power electronics and non-linear loads (such as variable speed drives, UPS, computers, servers, TV sets, etc.).

The presence of harmonics increases the RMS current in power networks. The circulation of harmonic currents through the system impedance creates voltage harmonics which produce voltage distortions and thus deteriorate the quality of the supply voltage. This leads to higher operating and energy costs, production/process downtimes, overheating and malfunction of equipment.

ACTIVE HARMONIC FILTERING

The active harmonic filters and power optimizers of the PQSine S-series from EPCOS are based on the latest state of the art in power electronics technology. They are installed in parallel to the polluting loads. The active filter analyzes the line current and its associated harmonics and generates a compensation current which neutralizes the harmonic currents and creates an almost sinusoidal waveform (see Figure 1). Figure 2 shows the total current harmonic distortion without PQSine S-series. Figure 3 shows the result with activated PQSine S-series, namely a cleaner grid.

In addition to eliminating the harmonics, the PQSine S-series active filter and power optimizer also actively balances the loads to all three phases, performs dynamic VAR compensation and even some transient compensation. These features avoid line resonance and ensure high performance and reliability.

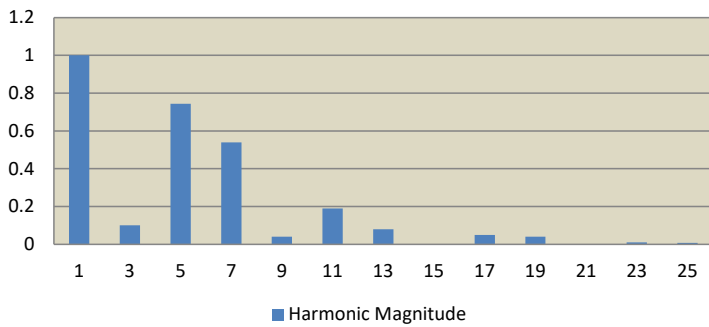
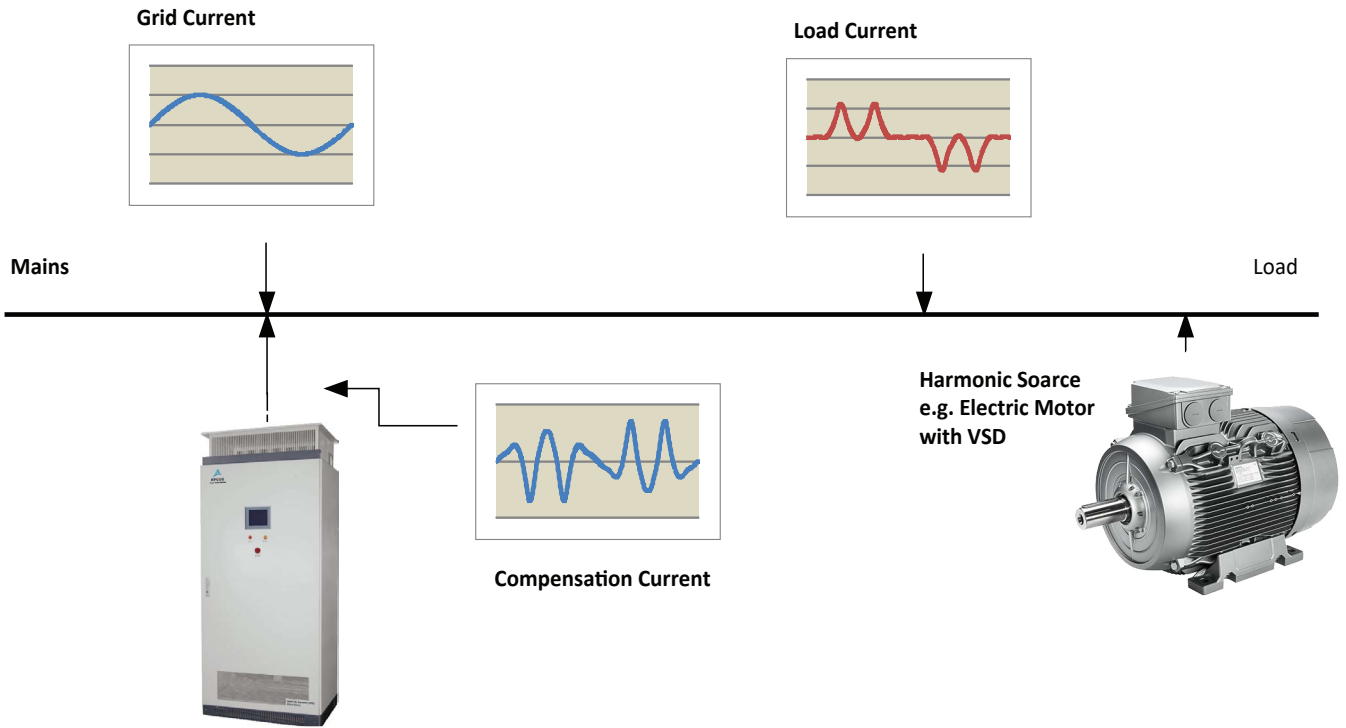

Figure 2

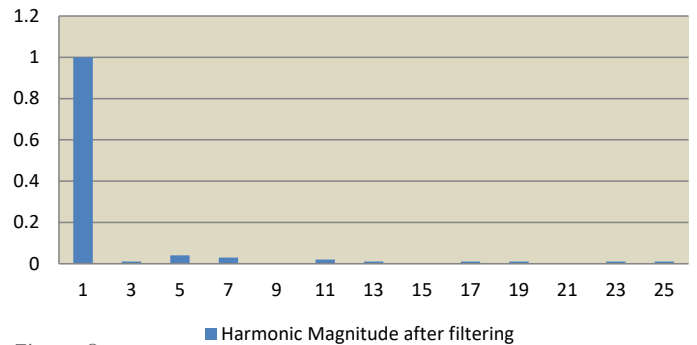

Figure 3

ACTIVE HARMONIC FILTERING

The PQSine S-series is an active harmonic filter system designed to eliminate harmonic oscillations and consequently reduce costs. PQSine S-series monitors the current signal and compensates the unwanted elements of the measured current. Thus, the filter ensures harmonic suppression independently of the number of loads. It also corrects the power factor, improving the system efficiency while reducing harmonic pollution.

Features

- | Harmonic compensation up to 50th harmonic (individually selectable)
- | Flicker compensation
- | Ultra-fast reactive power compensation (inductive and capacitive)
- | Load balancing between phases and unloaded neutral wire
- | *Compact design
- | Modular system extendable from 25 A and up
- | Grid resonance detection
- | Advanced digital control with SDC (Selective Direct Control) algorithm
- | Ethernet and Ethercat system for interconnection
- | User-friendly menu operation
- | High performance and reliability
- | Insensitive to network conditions
- | Simple installation

Typical applications

- | Fast current harmonics and reactive power suppression e.g. for:
- | Data centers
- | UPS systems
- | Green power generation (e.g. photovoltaics and wind turbines)
- | Sensitive equipment manufacturing (e.g. silicon wafer production, semiconductor production)
- | Industrial production machines
- | Electrical welding systems
- | Plastic industry machinery (extruders, injection molders)
- | Office buildings and shopping centers (3rd and triplenharmonic cancellation and neutral conductor unloading)

Safety features

- | Highest safety and reliability
- | Overload protection
- | Internal short-circuit protection
- | Overheating protection
- | Overvoltage and undervoltage protection
- | Inverter bridge protection
- | Resonance protection
- | Fan fault alarm

Depending on the requirements, APS Industrial offers either complete panels, wall-mounted cabinets or modules.

Floor-mounted Panels from 25 to 600A
Parallel operation beyond 600A possible



Wall-mounted Panel
25A up to 150A units available



Active Harmonic Filter - PQSine S Series

PART NUMBER	DESCRIPTION
3 PHASE 3 WIRE - WALL MOUNT	
B44066F3025S344	PQSW3025S344 25A 3P3W Wall mount
B44066F3035S344	PQSW3035S344 35A 3P3W Wall mount
B44066F3050S344	PQSW3050S344 50A 3P3W Wall mount
B44066F3075S344	PQSW3075S344 75A 3P3W Wall mount
B44066F3100S344	PQSW3100S344 100A 3P3W Wall mount
B44066F3150S344	PQSW3150S344 150A 3P3W Wall mount
3 PHASE 4 WIRE - WALL MOUNT	
B44066F4025S344	PQSW4025S344 25A 3P4W Wall mount
B44066F4035S344	PQSW4035S344 35A 3P4W Wall mount
B44066F4050S344	PQSW4050S344 50A 3P4W Wall mount
B44066F4060S344	PQSW4060S344 60A 3P4W Wall mount
B44066F4100S344	PQSW4100S344 100A 3P4W Wall mount
B44066F4150S344	PQSW4150S344 150A 3P4W Wall mount
3 PHASE 3 WIRE - FLOOR STANDING	
B44066F3100S315	PQSF3100S315 100A 3P3W Floor Standing
B44066F3150S315	PQSF3150S315 150A 3P3W Floor Standing
B44066F3200S315	PQSF3200S315 200A 3P3W Floor Standing
B44066F3250S315	PQSF3250S315 250A 3P3W Floor Standing
B44066F3300S315	PQSF3300S315 300A 3P3W Floor Standing
B44066F3350S315	PQSF3350S315 350A 3P3W Floor Standing
B44066F3400S315	PQSF3400S315 400A 3P3W Floor Standing
B44066F3450S315	PQSF3450S315 450A 3P3W Floor Standing
B44066F3500S315	PQSF3500S315 500A 3P3W Floor Standing
B44066F3550S315	PQSF3550S315 550A 3P3W Floor Standing
B44066F3600S315	PQSF3600S315 600A 3P3W Floor Standing
3 PHASE 4 WIRE - FLOOR STANDING	
B44066F4100S315	PQSF4100S315 100A 3P4W Floor Standing
B44066F4150S315	PQSF4150S315 150A 3P4W Floor Standing
B44066F4200S315	PQSF4200S315 200A 3P4W Floor Standing
B44066F4250S315	PQSF4250S315 250A 3P4W Floor Standing
B44066F4300S315	PQSF4300S315 300A 3P4W Floor Standing
B44066F4350S315	PQSF4350S315 350A 3P4W Floor Standing
B44066F4400S315	PQSF4400S315 400A 3P4W Floor Standing
B44066F4450S315	PQSF4450S315 450A 3P4W Floor Standing
B44066F4500S315	PQSF4500S315 500A 3P4W Floor Standing
B44066F4550S315	PQSF4550S315 550A 3P4W Floor Standing
B44066F4600S315	PQSF4600S315 600A 3P4W Floor Standing
EXTRA MODULES	
B44066F3025S300	PQSM3025S300 25A 3P3W Module
B44066F3035S300	PQSM3035S300 35A 3P3W Module
B44066F3050S300	PQSM3050S300 50A 3P3W Module
B44066F3075S300	PQSM3075S300 75A 3P3W Module
B44066F3100S300	PQSM3100S300 100A 3P3W Module
B44066F3150S300	PQSM3150S300 150A 3P3W Module
B44066F4025S300	PQSM4025S300 25A 3P4W Module
B44066F4035S300	PQSM4035S300 35A 3P4W Module
B44066F4050S300	PQSM4050S300 50A 3P4W Module
B44066F4060S300	PQSM4060S300 60A 3P4W Module
B44066F4100S300	PQSM4100S300 100A 3P4W Module
B44066F4150S300	PQSM4150S300 150A 3P4W Module
ACCESSORIES	
B44066F9999S230	7" HMI Colour

EMC COMPONENTS

APS Industrial can also offer many more components and systems for various power quality requirements:

- | Power Line Chokes
- | LCL Filters
- | Power line EMC Filters
- | Output Filters
- | EMC Filters for Shielded Rooms
- | EMC Feedthrough Capacitors
- | EMC Feedthrough Filters

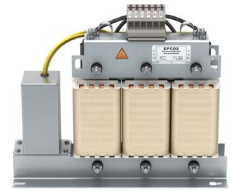

Sine-wave output filters for 3-phase systems

- | Rated voltage VR: 400/690 V AC, 50/60 Hz
- | Rated current IR: 10 A to 207 A
- | 3-line filters
- | Reduction of motor noise and eddy current losses
- | Generation of sinusoidal phase-to-phase voltage with low ripple
- | dv/dt reduction
- | Easy to install
- | Degree of protection: IP00
- | Optional housing for degree of protection IP21 can be ordered separately with ordering code B84143Q*R229
- | Optimized for long motor cables and operation under full load2)
- | Natural cooling
- | Wiring between inverter and filter must be shorter than 10 meters!
- | Designed with reference to IEC 60939 and UL1283
- | UL approved insulation system (system designation: T-EIS-CF1)



Filters for Shielded Rooms

- | .2- and 4-line-filters 16 to 32 A Multi-stage
- | .Stopband attenuation:
 - B84299*2*B/E001 150 kHz to 40 GHz
 - B84299*2*B/E003 14 kHz to 40 GHz
- | General-purpose use through design with separate lines without intercoupling
- | Use of single chokes. Thus the insertion loss values are not reduced under all operating current conditions and not when operated with artificial mains networks (AMN) or other equipment with high leakage currents
- | Insertion loss to EN 55017

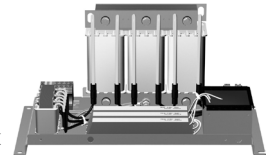

SineFormer

- | Filters for converters and power electronics
- | Rated voltage VR: 760 V AC
- | Rated current IR: 95 A to 320 A
- | Shielded motor cables are redundant
- | Motor noise reduction
- | Reduction of bearing current
- | Low dv/dt values - reduced eddy current losses
- | Easy to install
- | Compact design
- | Degree of protection: IP201)
- | Significant reduction of EMC disturbances on the line side
- | Optimized for long motor cables (up to 1000 m) and operation under full load2)
- | No integrated forced ventilation (maintenance-free)
- | No DC-link connection required



EMC COMPONENTS

| Design complies with EN 60939, UL 1283, CSA 22.2 No.8

Power line filters for 3-phase systems

- | Rated voltage VR: 520/300 V AC and 760/440 V AC
- | Rated current IR: 180 A to 1600 A
- | 3-line filters
- | Optimized leakage current
- | Easy to install
- | Very compact design
- | Optimized for operation under full load
- | Design complies with IEC 60939
- | UL and cUL approval



3-line LCL filters for converters and power electronics

- | Rated voltage VR: 300/520 V AC
- | Rated current IR: 16 A to 400 A
- | Open frame design
- | Power quality improvement for Active Infeed Converter (AIC)
- | High attenuation of pulse frequency to the grid side
- | Integrated damping resistors to suppress current oscillation
- | Degree of protection1): IP00
 - o IP20 (16 A ... 200 A) with optional cover B84143Q*R405
- | Modifications possible according customer specific requirements
- | For natural convection
- | Design complies with ENEC, UL and cUL



Feedthrough Capacitors

- | Rated voltage VR: 110 V AC to 440 V AC
- | Rated current IR: 16 A to 200 A
- | Rated capacitance CR: 0.0025 mF to 4.7 mF
- | MKP/MKT technology (dry, self-healing) Dielectric: polypropylene or polyester, metallized
- | Metal case, polyurethane potting (UL 94 V-0)
- | Compact dimensions
- | High insertion loss
- | Easy to install
- | High contact reliability thanks to central screw fixing
- | Design complies with IEC 60384-14
- | UL 60384-14 pending



aps MANUFACTURING CENTRE



ADVANCED
MANUFACTURING



VALUE ADD
SERVICES

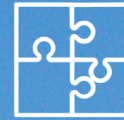

CUSTOMISED
SOLUTIONS



aps MANUFACTURING CENTRE

RECEIVING AND DESPATCH

NO PARKING LOADING ZONE



OUR LOCATIONS

National footprint with strategic local stockholdings.

APS Industrial is headquartered in Melbourne and in addition has a national network of offices in Adelaide, Perth, Sydney, Brisbane and Tasmania supported by strategic local stockholdings and expert technical and application knowledge.

apsindustrial.com.au

CONNECT WITH US



MELBOURNE

5-7 Corporate Ave,
Rowville, Melbourne VIC 3178
Ph: (03) 8514 3500
Sales: 1300 309 303
Email: vic@apsindustrial.com.au

SYDNEY

391 Park Rd, Block P,
Regents Park, NSW, 2143
Ph: (02) 8898 6200
Sales: 1300 309 303
Email: nsw@apsindustrial.com.au

BRISBANE

49 Borthwick Avenue,
Murarrie, Brisbane, QLD, 4172
Ph: (07) 3063 3100
Sales: 1300 309 303
Email: qld@apsindustrial.com.au

ADELAIDE

159-163 Caulfield Ave,
Clarence Gardens, SA 5039
Ph: (08) 8111 5100
Sales: 1300 309 303
Email: sa@apsindustrial.com.au

PERTH

5 Glyde Court, Malaga,
Malaga, Perth WA 6090
Ph: (08) 6118 5300
Sales: 1300 309 303
Email: wa@apsindustrial.com.au

HOBART

441A Macquarie Street,
South Hobart, TAS, 7004
Sales: 1300 309 303
Email: tas@apsindustrial.com.au